

RANGE EXTENDER DATA SHEET

FUNCTIONALITY

- Range Extender acts as a hopping point to “relay” messages across longer distances
- Extends the range of Cypress Solutions WPAN products; products such as the Man Down Pendant
 - Up to 4 Range Extenders can be used as part of a message relay mechanism
 - Transparent operation - messages from gateway to DCE device remain unchanged
- Available in two form factors:
 - External power** version for hookup to external 5-32 Volt DC power supply
 - Battery power** version with an internal battery for 10+ hours of unattended operation
- Weatherproof (IP67 enclosure) designed for permanent outdoor mounting
- Several mounting options such as bracket/pole mount, rooftop or base mount
- External antenna option for using high gain 2.4 Ghz antenna
- Range Extender can operate with multiple pendants and gateways simultaneously



**Battery Powered
Range Extender**

**Externally Powered
Range Extender**



SPECIFICATIONS

- Industrial Temperature Range: -40C to +60 C
- Weatherproof IP67 Enclosure suitable for permanent out door installation
- 5-32 VDC power input (external power version)
- 10 hour continuous operation battery powered version with battery recharge connector
- Optional External (RP-SMA) antenna connection
- Compatible with Pendant/Gateway firmware 2.0

Top View of Range Extender

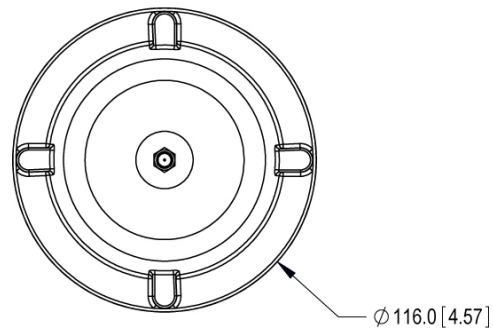

Battery Powered Range Extender

RP-SMA connector
for external antenna

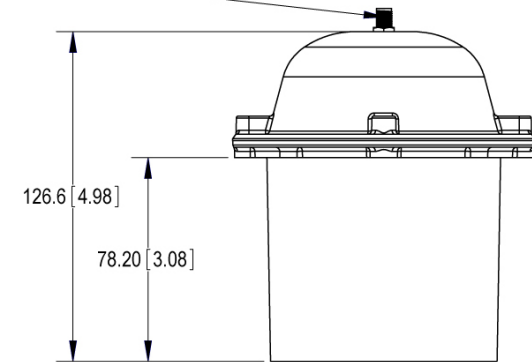

Externally Powered Range Extender

RP-SMA connection for
external antenna

